

Model 3050-TE for Cryo-Recovery Plants

A Total Solution for Sub-0.1 ppmv Industrial Moisture Analysis

INCREASE RECOVERY EFFICIENCY AND MINIMIZE DOWNTIME THROUGH BETTER DRYER OUTLET MONITORING

A Total Solution Provides Assurance

At AMETEK Process Instruments, we know the difficulties associated with accurately measuring moisture concentrations below 0.1 ppmv (100 ppbv). After all, we manufacture analyzers that are accurate, sensitive, and responsive at concentrations below one ppbv moisture. With this knowledge and ability, we have adapted our ppbv quartz-crystal microbalance technology into a Zone I/Division 1 industrial package suited for natural gas processing.

The Model 3050-TE solution is specifically designed to monitor the sub-0.1 ppmv moisture content of the natural gas feeding turbo-expanders and other cryogenic processes. The Model 3050-TE measures moisture directly in concentration (ppmv)—the most meaningful measurement parameter.

When attempting to detect and measure very low concentrations of moisture, proper selection and use of sample-wetted components is ultra-critical. If you use the wrong sample tubing, or if it is too long, or if it is not properly heat traced, the minute changes in process moisture concentration that you wish to monitor will never reach the analyzer for measurement.

To ensure you a successful and easy analyzer installation, the 3050-TE is an integrated solution package for your turbo-expander process. It includes all sample handling components from the sample tap through the analyzer.



Model 3050-TE for Cryo-Recovery Plants

In addition to a proper sample handling system, it is crucial for the analyzer itself to provide the sensitivity, accuracy, and speed of response necessary for this application. This is why the 3050-TE is based upon quartz-crystal microbalance (QCM) technology.

Quartz-crystal Microbalance Technology: Accurate. Reliable. Verifiable. Responsive.

QUARTZ-CRYSTAL MICROBALANCE — THE SAFEST CHOICE

Dramatically Better Accuracy

Consider the basic accuracy specification of the 3050-TE: 0.01 ppm or $\pm 10\%$ of reading from 0.01 ppm to 100 ppm by volume. In the table below, we've compared this to the published accuracy of an aluminum-oxide humidity analyzer. The data in the table is based upon the specifications of a newly calibrated probe which is typically claimed to be $\pm 3^\circ\text{C}$ dew point for gases drier than -65°C dew point. The aluminum-oxide's calibration drift, temperature instability and other sources of error are not typically taken into account in published specifications. Aluminum-oxide's speed of response is another issue.

Actual ppmv Moisture	Model 3050-TE Accuracy	Aluminum-Oxide ⁽¹⁾ Accuracy
0.05	± 0.01 ppmv	+0.038%/-0.022 ppmv
0.1	$\pm 10\%$ of reading	+71.8%/-42.9% of reading
0.5	$\pm 10\%$ of reading	+62.7%/-39.5% of reading
1.0	$\pm 10\%$ of reading	+59.6%/-38.2% of reading
10.0	$\pm 10\%$ of reading	+30.9%/-24.0% of reading

(1) Based upon accuracy of $\pm 3^\circ\text{C}$ below -65°C dew point. Dew point conversions referenced to 14.7 psia.

Long Term Stability Reduces Maintenance Costs

The 3050-TE analyzer is inherently more stable due to its quartz-crystal microbalance technology. The stability of the vibrating quartz crystal eliminates the need for factory recalibrations. This means that you will forever eliminate those costly, routine maintenance projects that are associated with aluminum-oxide-based sensors. But don't take our word about the 3050-TE's stability; ask the analyzer itself! Every

3050-TE comes equipped with an internal verification system that consists of both zero and span challenges that are created using actual sample gas.

Built-in Verification Capability

Through its built-in zero module and internal moisture generator, the 3050-TE will inspire your confidence in its data. On a programmed schedule or whenever you feel it's necessary, you can route the process gas through the 3050-TE's internal zero gas generator and its internal moisture generator, giving you a zero reference and a span calibration standard based upon the actual process gas. The 3050-TE automatically zeroes itself and compares its moisture measurement with the NIST-traceable known value of the internal moisture generator. If necessary, the analyzer can make small corrections to its calibration automatically. If the sensor fails to report the correct value of the moisture generator, the analyzer will provide an alarm to alert you to the situation. With the 3050-TE, you will always be confident that the analyzer is responsive to the moisture present in the sample gas.

Gain Peace of Mind Through Active Feedback

The Model 3050-TE is an active device. It is constantly monitoring itself for its frequency of oscillation, sample flow, sample pressure, operating temperature, ambient temperature, and other telling parameters. In addition, the QCM sensor is continually challenged with increasing and decreasing moisture levels inherent in the non-equilibrium nature of its operation. Through this system of active feedback, the 3050-TE keeps you confident in its performance. Remember, if at any time you doubt the analyzer's readings, you can activate the built-in verification functions.

The 3050-TE is simply the best analyzer and the easiest choice available for your cryogenic turbo-expander process. Make the decision to protect your process, your revenue, and your peace of mind today.



THE QUARTZ-CRYSTAL SENSOR

The heart of the 3050-TE analyzer is a quartz-crystal microbalance (QCM) sensor and analysis technique developed by AMETEK specifically for highly accurate moisture measurements. The sensor consists of a pair of electrodes that support the QCM sensor. When voltage is applied to the sensor, a very stable oscillation occurs.

The faces of the oscillator are covered with a hygroscopic polymer. As the amount of moisture sorbed onto the polymer varies, the mass of the QCM changes producing a corresponding change in the frequency of oscillation. These easily measurable changes have a direct relation to the moisture concentration of the sample gas.

Process Gas Cycle

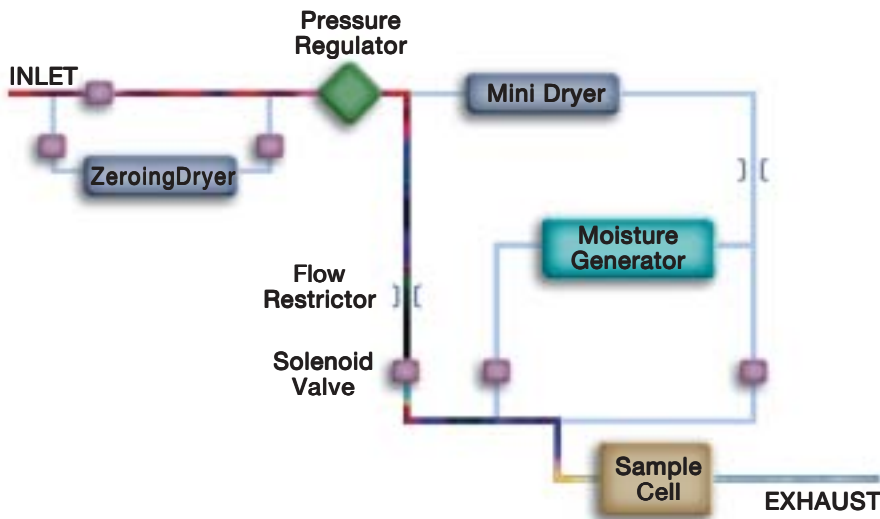

Reference Gas Cycle

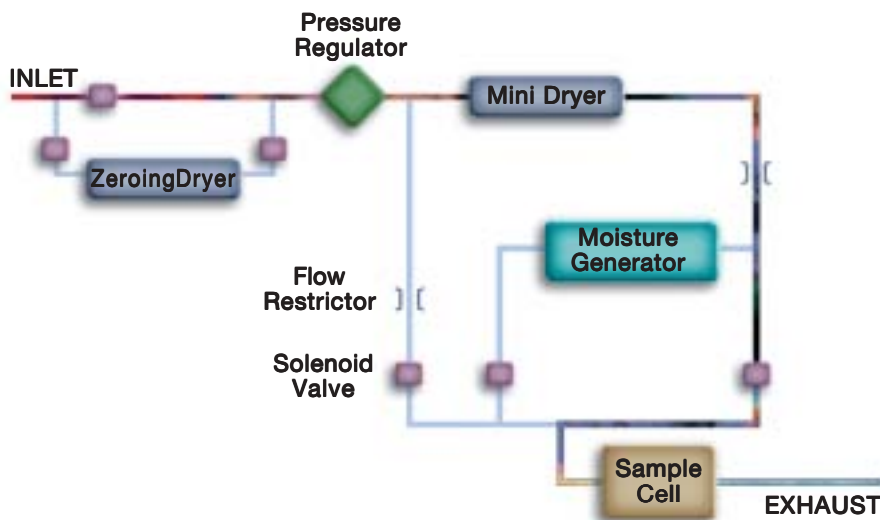

Non-equilibrium Operating Theory of Quartz-crystal Microbalance

Moisture sensors are notoriously slow because they need a long time to equilibrate, especially when drying down. Non-equilibrium operation is a special technique developed as a means of improving a moisture sensor's speed of response. It works by systematically cycling the sensor between the process gas and a dry reference gas.

During the process gas cycle (top, left), moisture molecules accumulate on the surface of the QCM sensor. During the reference gas cycle (bottom, left), these water molecules are swept off the surface of the sensor by the dry gas flow. Since there is no waiting for equilibrium, the system provides a measurement of moisture concentration every cycle.

The number of water molecules that accumulate on the surface of the sensor is a function of the difference in moisture between the process gas and reference gas. The analyzer compares the process gas with the known, dry reference as opposed to trying to measure an absolute value that only occurs once the equilibrium has been achieved. When a high moisture event occurs, the 3050-TE responds quickly to alert you to the problem. After the high moisture event passes, the non-equilibrium nature of the 3050-TE means that no long dry down period is ever needed before you will get accurate sub-ppmv measurements.

PERFORMANCE SPECIFICATIONS

System Components: 3050-TE analyzer, heated sample probe (pipe thread or flange), 3 meters of special, heat-traced sample line

Technology: Quartz-Crystal Microbalance

Range: 0.01 to 100 parts-per-million by volume (ppmv)

Reference Gas: Continuously produced using actual sample gas

On-Line Verification: Internal zero gas generator plus an internal moisture source with NIST-traceable calibration. These systems enable on-demand verification of analyzer accuracy and responsiveness without uninstalling the analyzer. Verification function can be triggered remotely with a voltage signal.

Accuracy: ± 0.01 ppmv or $\pm 10\%$ of reading, whichever is greater

Reproducibility: ± 0.005 ppmv or $\pm 5\%$ of reading, whichever is greater

Limits of Detection: 0.01 ppmv

Moisture Generator: 1.0 ppmv nominal; calibration is NIST-traceable

QCM Response Time: Near real time. Computer-enhanced response, which may lead to errors, is not required to obtain quick wet-up or dry-down response.

Sensitivity: 0.005 ppm or 1% of reading, whichever is greater

Allowable Inlet Pressure: 7 to 200 Bar (100 to 3000 psi) [with pressure-reducing sample probe providing 3.45 Bar (50 psi) maximum pressure to the analyzer]

Exhaust Pressure: 0 to 1 Bar (0 to 15 psi)

Sample Gas Temperature: 0° to 100° C (32° to 212° F); analyzer performance is immune to changes in sample gas temperature

Gas Flow Requirements: Approximately 1.0 slpm

Outputs: Isolated 4 to 20 mA analog signal, keyboard selectable; 12 bit (0.025%) resolution, RS232 and RS485 serial communication ports

Alarms: Two contact closures: system and data valid alarms

Ambient Temperature Limits: -40° to $+60^{\circ}$ C (-40° to 140° F)

Utility Requirements

120/230 $\pm 10\%$ VAC, 50/60 Hz, 150W maximum
Instrument Air:

Analyzer: 5 to 7 Bar (70 to 100 psi)

Cabinet Cooler: 6 to 10 Bar (90 to 150 psi)

Approvals and Certifications

UL/CSA General Safety Requirements

UL/CSA Class I, Division 1, Groups B, C, D T6

ATEX Directive; II 2 G EEx de IIC T6

Complies with all Relevant European Directives

Russian Gosstandart Pattern Approval

Russian Ex Proof Certification 1ExdIICT6X

One of a family of innovative process analyzer solutions from AMETEK Process Instruments. Specifications subject to change without notice.

USA - Pennsylvania
150 Freeport Road
Pittsburgh, PA 15238
Ph. 412-828-9040
Fax 412-826-0399

USA - Delaware
455 Corporate Blvd.
Newark, DE 19702
Ph. 302-456-4400
Fax 302-456-4444

CANADA
2876 Sunridge Way N.E.
Calgary, AB T1Y 7H9
Ph. 403-235-8400
Fax 403-248-3550

**MANUFACTURING
LOCATIONS**



PROCESS INSTRUMENTS
www.ametekpi.com

© 2004, by AMETEK, Inc. All rights reserved.
3050-TE (01/20/04)



**SUPPORT
LOCATIONS**

USA - Texas
Ph. 281-463-2820
Fax 281-463-2701

CHINA - Beijing
Ph. 86-10-85262111
Fax 86-10-85262141

CHINA - Shanghai
Ph. 86 21 6426 7049
Fax 86 21 6426 7054

FRANCE
Ph. 33 1 30 68 69 20
Fax 33 1 30 68 69 29

GERMANY
Ph. 49 21 59 91 36 0
Fax 49 21 59 91 3680

MIDDLE EAST - Dubai
Ph. 971-4-881 2052
Fax 971-4-881 2053

SINGAPORE
Ph. 65-6484-2388
Fax 65-6481-6588